

Oleksandra HOTRA
Oksana BOYKO

TEMPERATURE MEASURING DEVICE BASED ON THIN FILM THERMORESISTORS

ABSTRACT *Bridge resistive transducers based on thin film thermoresistors were investigated. The temperature dependencies of resistance errors introduced by the method of two-layer structure are obtained. The microprocessor temperature device is elaborated on the base of shifted two-layer resistive structures.*

Keywords: *temperature measurements, thermoresistors, bridge circuits*

1. INTRODUCTION

Virtually all the phenomena that around the man are directly or indirectly connected with temperature and its measurement [1]. Different measuring transducers are applied for temperature measurement and control. Among them, thermoresistive transducers belong to the most common devices [2]. The main disadvantage of the mass-produced thermoresistive primary transducers such as copper and platinum RTD is the long time of output signal setting, and a transition period of the resistance value setting under temperature

Oleksandra HOTRA, Ph.D., D.Sci.

e-mail: o.hotra@pollub.pl

Lublin University of Technology

Oksana BOYKO, Ph.D

e-mail: oxana_bojko@ukr.net

Lviv National Medical University

influence [3]. In general, the response time of the RTD ranges from 1 to above 5 seconds [4]. For the primary thermoresistive transducers TCП-8041P, the response time is less than 4.6 s, for PT202 100RTD temperature probe – 5.2 s, for 121LF Spring Articulated Straight Surface Probe, and 204CTLF Paddle Probe – 2 s. These factors limit the application of metal RTD's for temperature measurement in the heat fluxes, rapid heat processes and high-precision fine temperature regulation systems. For reducing the time of output signal setting of primary thermoresistive, it is reasonable to use the film thermoresistors in the designed construction [5, 6, 7].

The investigation and improvement of the primary resistive transducers based on film thermoresistors is an up-to-date task of thermometry.

2. INVESTIGATION OF THE BRIDGE RESISTIVE TRANSDUCERS BASED ON FILM THERMORESISTORS

Different construction and technology methods of thermoresistive bridge transducers design are used. We investigated the measuring bridge (Fig. 1) in which the temperature-dependent resistors with opposite sign of temperature coefficient of resistance (TCR) are applied [8].

The resistors R_1 , R_{21} , and R_{31} are made in the lower layer of the resistive structure on dielectric substrate with positive TCR. The resistors R_{22} , R_{32} , R_4 are made in the shifted upper resistive layer with negative TCR.

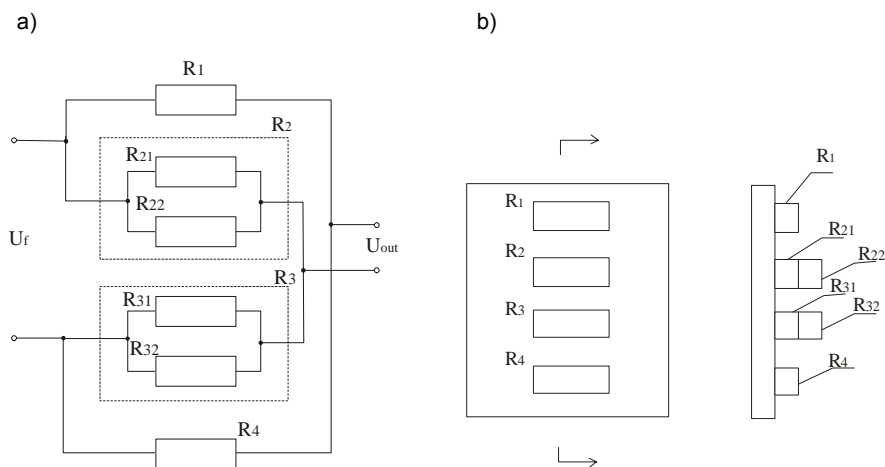

Fig. 1. Film thermoresistive transducers: a) principal schematic, b) arrangement details

The equivalent resistance values of the resistors R_2 , and R_3 made of the double layers could be calculated as follows (for calculating the R_3 value, in the formula (1) R_{21} should be replaced with R_{31} , and R_{22} – with R_{32}):

$$R_2 = \frac{R_{21}(1 + \alpha t) \cdot R_{22}(1 - \alpha t)}{R_{21}(1 + \alpha t) + R_{22}(1 - \alpha t)}, \quad (1)$$

where R_{21} , R_{22} are the values of the resistance at 0°C of the resistors with positive and negative TCR, t is the value of the measured temperature in degrees Celsius, α is the TCR.

If the nominal values of the resistance of the resistors R_{21} , R_{22} are equal, the formula (1) for the resistance of the resistor R_2 can be simplified:

$$R_2 = \frac{R_{20}}{2} [1 - (\alpha t)^2]. \quad (2)$$

where R_{20} is the nominal value of the resistance of the resistors R_{21} , R_{22} at 0°C .

The dependence of the value of absolute error of the resistance R_2 (made of double film layer) on temperature change is described by the expression:

$$\Delta R_2 = -\frac{R_{20}}{2} (\alpha t)^2. \quad (3)$$

Accordingly, the relative error equals:

$$\delta_{R_2} = -(\alpha t)^2. \quad (4)$$

The graphs of the relative error of equivalent resistance R_2 in the temperature range from -10°C to $+150^\circ\text{C}$ for different values of α are shown in Figure 2.

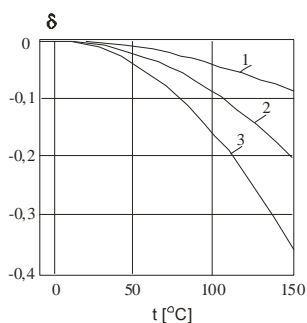

Fig. 2. The dependencies of the relative error of equivalent resistance of the resistor R_2 on temperature for different values of TCR: 1 – $\alpha = 0.002$; 2 – $\alpha = 0.003$; 3 – $\alpha = 0.004$

It can be seen from the graph dependencies in Figure 2, that the parallel connection of the resistors with different signs of temperature coefficients does not ensure a high temperature stability of the resistance R_2 which sharply falls off with the increase of both temperature and the values of TCR of resistors.

It is possible to reduce the resistance error if different nominal values of the resistance of the resistors at 0°C are matched. In this case, the value of the resistance of the resistor with positive TCR should be less than the value of the resistance of the resistor with negative TCR, that is $R_{21n} < R_{22n}$. The nominal values of resistance of the resistors R_{21} i R_{22} would be equal, respectively:

$$R_{21n} = kR_{2n}, \quad R_{22n} = \frac{k}{k-1} R_{2n}, \quad (5)$$

where k is the quotient of the nominal values of the resistance of the resistor with positive TCR and the equivalent value of resistance of the resistor R_2 , and R_{2n} is the nominal equivalent value of the equivalent resistance of the resistor R_2 .

The temperature dependence of equivalent values of resistance of the resistors R_2 and R_3 is described by the following expression:

$$R_2 = R_3 = \frac{kR_{2n}(1 - \alpha^2 t^2)}{k + (k-2)\alpha t}. \quad (6)$$

The temperature dependencies of the absolute errors ΔR and relative errors δ of the equivalent value of resistance of the resistors R_2 and R_3 are given by the following expressions:

$$\Delta R = R_{2n} \left(1 - \frac{k(1 - \alpha^2 t^2)}{k + (k-2)\alpha t} \right), \quad (7)$$

$$\delta = 1 - \frac{k(1 - \alpha^2 t^2)}{k + (k-2)\alpha t}. \quad (8)$$

The temperature dependencies of the relative error δ for different values of the coefficient k are shown in Figure 3, and for different values of TCR α are given in Figure 4.

It can be noticed from the dependencies in Figures 3 and 4, that the maximum value of relative error δ over the temperature range $-10\dots 150^\circ\text{C}$ does not exceed 0.05 for $k = 1,4$ and $\alpha \leq 0.003$.

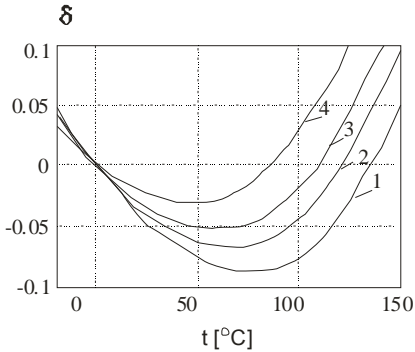

Fig. 3. The temperature dependencies of the relative error δ at $\alpha = 0.004$ for different values of the coefficient k :
 1 – $k = 1.3$; 2 – $k = 1.35$; 3 – $k = 1.4$;
 3 – $k = 1.5$

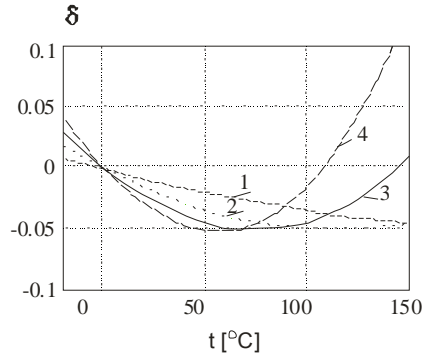

Fig. 4. The temperature dependencies of the error at $k = 1,4$ for different values of TCR: 1 – $\alpha = 0.001$; 2 – $\alpha = 0.002$;
 3 – $\alpha = 0.003$; 4 – $\alpha = 0.004$

3. DESIGN OF MICROPROCESSOR TEMPERATURE MEASURING DEVICE

The primary transducers based on two-layer film structures can be used for design of temperature measuring devices in non-aggressive media, for control of temperature regimes in active thermostats, for compensation of the thermoelectric transducer cold-junction temperature influence, and temperature compensation of the value of electromotive force in standard cells.

A temperature measuring device with temperature primary transducer based on the film resistors of two-layer shifted structure have been designed (Fig. 5).

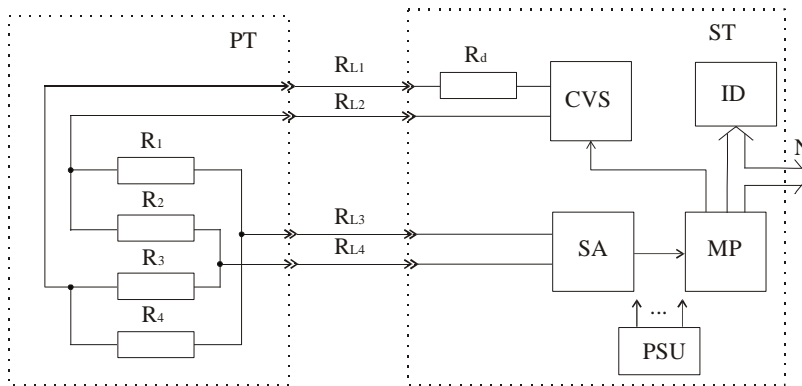

Fig. 5. The scheme of temperature measuring device

The primary transducer PT is connected to the secondary transducer ST by a four-wire connection marked R_{L1} , R_{L2} , R_{L3} and R_{L4} .

The secondary transducer consists of a separated galvanically controlled voltage stabilizer CVS, an amplifier of the PT output signal (SA), a microprocessor MP, an indicator device ID, and a power supply unit PSU.

In order to reduce the influence of the measuring current of the primary transducer on the accuracy of the measurement, the resistive bridge circuit is supplied by the signal from microprocessor only when measurements are performed. At absence of supply voltage on bridge circuit the shift voltage of zero level of SA and analogue-to-digital converter of the microprocessor MP are measured.

Accordingly to the control signal from the MP, the stabilizer CVS sets gives the voltage U_f through resistor R_d which is put to the supply terminals of the resistive circuit PT. The output voltage of this circuit is defined as:

$$U_o = \frac{U_f R_m}{R_d + R_m} \cdot \left(\frac{R_3}{R_2 + R_3} - \frac{R_4}{R_1 + R_4} \right), \quad (9)$$

where $R_m = \frac{(R_1 + R_4)(R_2 + R_3)}{R_1 + R_4 + R_2 + R_3}$ is the total resistance of the bridge circuit.

From the expression (9) it can be seen that the output voltage of the bridge circuit depends on the value of the supply voltage U_f and the resistance of additive resistor R_d . By adjusting the supply voltage or the resistance of additive resistor, one can obtain the desired value of the output voltage of bridge circuit for different film resistors.

The absolute nonlinearity error of the output voltage is described by the following expression:

$$\Delta U(t) = U_o(t) - \frac{U_{o\max} \cdot t}{t_{\max}}. \quad (10)$$

The relative error δ , and the full scale error equals:

$$\delta = \frac{U_o(t) \cdot t_{\max} - U_{o\max} \cdot t}{U_o(t) \cdot t_{\max}}, \quad \gamma = \frac{U_o(t) \cdot t_{\max} - U_{o\max} \cdot t}{U_{o\max} \cdot t_{\max}}. \quad (11)$$

The graph dependencies of the full scale nonlinearity error of the output voltage on temperature within the range from -10 to +150°C at the maximum value of output voltage $U_{o\max} \approx 15$ mV are shown in Figure 6.

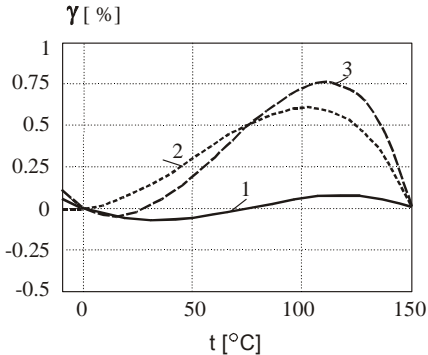

Fig. 6. Graph dependencies of the full scale nonlinearity error of the output voltage on temperature at different values of k and α :
1 – $k = 1.4$; $\alpha = 0.002$; **2** – $k = 1.4$; $\alpha = 0.003$; **3** – $k = 1.2$; $\alpha = 0.004$

From these dependencies it could be seen that the error does not exceed 0.1% at $k = 1.4$ and $\alpha = 0.002$.

The output voltage of the bridge circuit is set on input of the amplifier SA. In consequence, the output voltage of the amplifier is set on the converting input of an analogue-to-digital converter of the microprocessor MP.

After processing of the input data, the MP passes the result on the indicator device in the form of a numerical code:

$$N(t) = \Delta U \cdot t \cdot k_1 \cdot k_2 \cdot k_{3i}, \quad (12)$$

where k_1 is the amplification coefficient of the amplifier, k_2 is the gain factor of an analogue-to-digital converter of the microprocessor MP, k_{3i} is the transformation coefficient of MP, and ΔU is the change in the output voltage of the primary transducer for a temperature change of 1°C.

For the i -th measurement range, the additive linearization is realized by correct matching the coefficient k_{3i} .

For $\Delta U \cdot k_1 \cdot k_2 \cdot k_{3i} = 1$, the output code equals numerically to the measuring temperature.

The measurement time is defined by the response time of the bridge circuit, the conversion time of ADC, and the data processing time in MP, but the main contribution has the response time of the bridge circuit. The time constant of the bridge circuit (the time necessary for reaching 0.63 of the final temperature value in a step change) obtained experimentally was equal $\tau = 0.1$ s.

The relationship between the absolute error of temperature measurement and the elapsed time, for the temperature change of 10°C, is shown in Figure 7.

In order to achieve the accuracy of 0.5%, the elapsed time interval 0.5 s is needed.

Fig. 7. The relationship between the absolute error of temperature measurement and the elapsed time, for the temperature change of 10°C

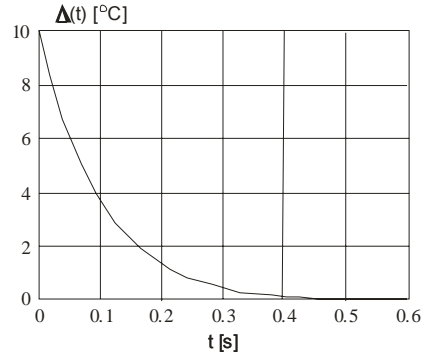

4. INVESTIGATION OF THE INFLUENCE OF THE RESISTANCE OF CONNECTION WIRES ON MEASUREMENT ACCURACY

In temperature measurements using the thermoresistive transducers, an error component is introduced by connection wires. In order to decrease the connection wires influence, the three- and four-wire connections are applied [9-11]. In this case, the four-wire connection with the additive resistor is employed.

The resistances of the connection wires R_{L3} , R_{L4} are connected to the high-resistance input of the operation amplifier, and in consequence do not influence the accuracy of output voltage formation. The resistances of the wires R_{L1} , R_{L2} are connected in series with the additive resistor R_d , and influence the accuracy of output voltage formation, either.

Taking into account the resistance of the wires, the output voltage of the primary transducer could be found from the following expression:

$$U_{out} = \frac{U_f R_m}{R_d + R_{L1} + R_{L2} + R_m} \cdot \left(\frac{R_3}{R_2 + R_3} - \frac{R_4}{R_1 + R_4} \right). \quad (13)$$

The absolute error due to the influence of the resistance of connection wires is expressed as:

$$\Delta U_L = \left(\frac{U_f R_m}{R_d + R_{L1} + R_{L2} + R_m} - \frac{U_f R_m}{R_d + R_m} \right) \cdot \left(\frac{R_3}{R_2 + R_3} - \frac{R_4}{R_1 + R_4} \right). \quad (14)$$

The full scale error δ_L equals:

$$\delta_L = \frac{\Delta U_L}{U_{out,max}} \cdot 100\%. \quad (15)$$

The temperature dependencies of the full scale error δ_L introduced by the resistance of connection wires for different values of the resistance of the additive resistor R_d and different values of the resistance of connection wires (1 – $R_L = 1$ Ohm, 2 – $R_L = 2$ Ohm; 3 – $R_L = 5$ Ohm) are depicted in Figure 8.

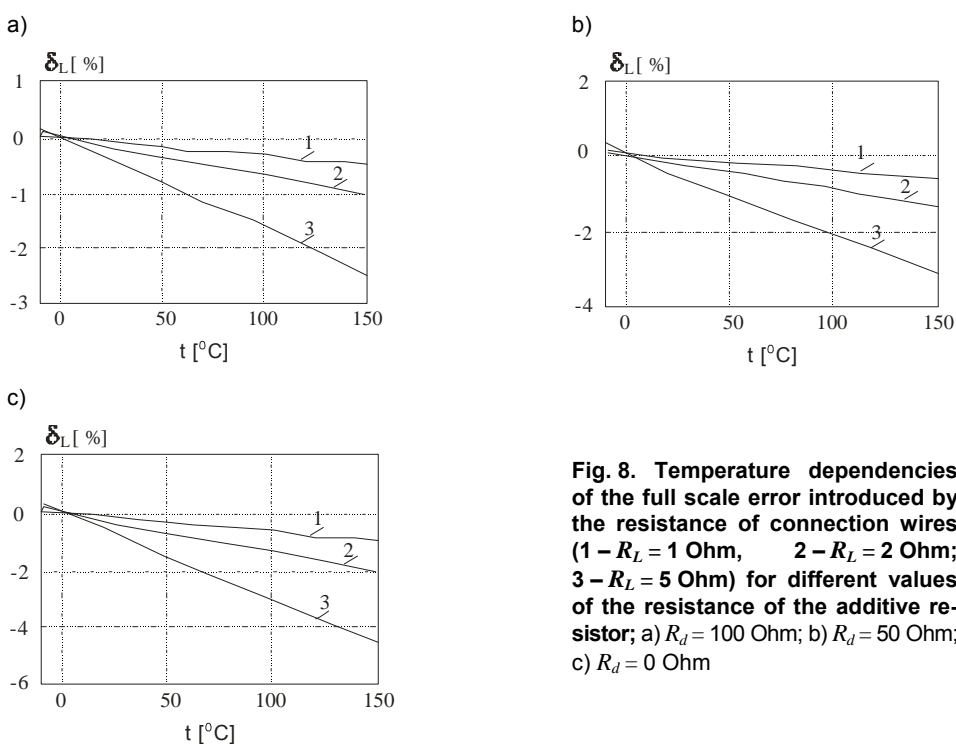

Fig. 8. Temperature dependencies of the full scale error introduced by the resistance of connection wires (1 – $R_L = 1$ Ohm, 2 – $R_L = 2$ Ohm; 3 – $R_L = 5$ Ohm) for different values of the resistance of the additive resistor; a) $R_d = 100$ Ohm; b) $R_d = 50$ Ohm; c) $R_d = 0$ Ohm

At an increase in the value of the resistance of additive resistor R_d , the influence of the resistance of connection wires on the measurement accuracy decreases. A considerable increase of the resistance of the additive resistor R_d influences on the total error of the bridge circuit. The smallest value of the transformation error is obtained at $R_d = 100$ Ohm. In this case, at the change of resistance of connection wires up to 2 Ohm the additive error up to 1% appears.

The influence of the connection wires could be compensated with the change of the resistance of the additive resistor R_d .

5. CONCLUSIONS

The use of thin film technology for the design of thermoresistors with different TCR allows creating the temperature primary transducers with good technical characteristics. The main advantage of film thermoresistors is a short time of output signal setting and a high sensitivity. The presented bridge circuit based on a shifted two-layer resistive structure exhibits the nonlinearity error of the output signal less than 0.1%.

The usage of a four-wire connection PT to ST, and an additive resistor allows reducing the influence of the resistance of the connection wires on measurement results.

Experimental investigations of the resistive bridge circuits were performed for different resistive alloys. Different values of TCR were obtained by adjusting the percentage content of materials of some resistive elements, and the total measurement error does not exceed 0.15%. In a step temperature change, the response time was less than 0.5 s at 0.5% accuracy, and for a velocity of change of the measured temperature over time equal 2°C/s the accuracy of 0.25% was achieved. The conducted experimental investigations confirmed the theoretical considerations of the application of the two-layer shifted structure film resistors for the design of the temperature primary transducers.

LITERATURE

1. Hotra O., Boyko O.: Tranzystorowo-rezystancyjny układ kompensacji wpływu temperatury wolnych końców termopary, *Prace Instytutu Elektrotechniki, Zeszyt 249*, s. 21-27, 2011.
2. Hotra O.Z.: *Microelectronic elements and devices for thermometry*, Liga-Press, Lviv, 2001.
3. Kim J., Shin Y., Yoon Y.: A Study on the Fabrication of an RTD (Resistance Temperature Detector) by Using Pt Thin Film, *Korean J. Chem. Eng.*, 18(1), pp. 61-66, 2001.
4. Curtis D.: *Johnson Process Control Instrumentation Technology*, Prentice Hall, 2006.
5. Matviiv V., Kochan V., Pirus R.: Temperature measuring device, Patent USSA №1652831, 1991.
6. Post J. W., Bhattacharyya A., Imran M.: Experimental results and a user-friendly model of heat transfer from a thin film resistance temperature detector. *Applied Thermal Engineering*, pp. 116-130, 2009.

7. Priest J.: Temperature and Its Measurement, Encyclopedia of Energy, V6, pp. 45-54, 2004.
8. Boyko O., Hotra Z., Hotra O., Lopatynskij I.: Temperature measuring device, Patent UA № 34039, 2001.
9. Sen S.K.: An improved lead wire compensation technique for conventional two wire resistance temperature detectors (RTDs), Measurement, 39, pp. 477-480, 2006.
10. Maiti T.K., Kar A.: A new and low cost lead resistance compensation technique for resistive sensor, Measurement, 43, pp. 735-738, 2010.
11. Sen S.K., Pan T.K., Ghosal P.: An improved lead wire compensation technique for conventional four wire resistance temperature detectors (RTDs), Measurement, 44, pp. 842-846, 2011.

Manuscript submitted 18.06.2012

PRZYRZĄD POMIARU TEMPERATURY NA PODSTAWIE CIENKOWARSTWOWYCH TERMOREZYSTORÓW

Oleksandra HOTRA
Oksana BOYKO

STRESZCZENIE *W artykule opisano przetworniki mostkowo-rezystancyjne zbudowane na bazie cienkowarstwowych termorezystorów. Otrzymano temperaturowe zależności opisujące niedokładności przetwarzania spowodowane przez dwuwarstwową strukturę termorezystancyjną. W oparciu o dwuwarstwową strukturę przetwornika opracowano mikroprocesorowy przyrząd pomiaru temperatury.*

Słowa kluczowe: *pomiary temperatury, termorezystory, układy mostkowe*

